



DX480/520LCA-HD (HEAVY DUTY)

Engine Power : (SAE J1349) 238 kW (318 HP) at 2,000 rpm / 238 kW (318 HP) at 2,000 rpm

Operational Weight : 48,400 - 50,200 kg / 51,100 - 52,900 kg

Bucket capacity(SAE) : 1.8 - 2.86 m³ / 0.92 - 3.28 m³



Key points



Excellent Quality, reliability & durability

DX480LCA-HD & DX520LCA-HD have been built for the industry's best productivity and cycle times thanks to great machine stability, digging forces and significantly increased swing torque.

COMFORT & HANDLING

- Spacious, the newest design cab with low noise and vibration levels.
- Improved all-round visibility.
- Air conditioning with climate control & Air suspension seat with heater.
- Joystick and switches integrated in armrest for precise operation. All switches grouped together and ergonomically positioned.
- 3 work and 3 power modes for maximum efficiency.
- New, user-friendly LCD color monitor with full access to machine settings and maintenance data.

RELIABILITY

- Full Heavy-duty specification durable in any severe working condition.
 - Heavy-duty boom, arm, and cylinders.
 - H class bucket and newly designed tooth.
 - ROPS (Roll-Over Protection Structure) Cabin.
 - Heavy-duty under cover.
 - Full track guard.
- Mechanical type engine with high-efficient filters.
- Heavy-duty X-shaped undercarriage with integrated track spring and idler plus durable box section track frame and self-lubricating sealed links.
- Reliable and well protected hydraulic, electric and lubrication routings with simple, optimized layout.

PERFORMANCE & PRODUCTIVITY

- e-EPOS System (Electronic Power Optimizing System) and hydraulic power boost function for optimized combustion and minimized emissions.
- 28% increased swing torque and 12% increased traction force compared to previous model.
- Breaker piping with filters.

FUEL EFFICIENCY

- 5% more fuel efficient than previous model.
- Efficient conversion of engine output into hydraulic performance for better fuel efficiency and lower costs.
- Best-in-class double element air cleaner and pre-filtered Turbo dust separator for maximum fuel efficiency.

MAINTENANCE & SAFETY

- Simplified electronics.
- Easy access to all maintenance components.
- Maintenance data available directly from control panel.
- Fuel pre-filter with water separator.
- PC access for maintenance and repairs.
- Self-diagnosis function.
- Reliable Doosan parts.
- High battery capacity (150 Ah).
- Highly lubricated bushings to optimize greasing.



Reliability



Full heavy-duty specification durable in any severe working condition.



Heavy-duty cabin



Mechanical engine with high-efficient filters



Full track guard & Full heavy-duty undercarriage parts



Improved hydraulic hoses



Heavy-duty under cover



Heavy-duty boom, arm & cylinders



EM bush



Newly designed H class bucket & tooth



Performance & Stability

Maximum performance by Doosan in house engine

- Doosan in house engine perfectly harmonized with the hydraulic system and provides strong power.
- Mechanical engine provides high resistance to moisture, dust, and bad fuel quality.

Doosan DX480LCA-HD & DX520LCA-HD engine

Make and model	DOOSAN DE12TIS - 6 cylinders
Barometric pressure	760 mmHg (20°C)
Cooling fan	ø 914.4 mm , 8-blade, sucker
Alternator	12V x 50A
Double element air cleaner	Installed - ø 381 mm x 530 mm
Muffler	Installed - ø 400 mm x 920 mm
Power (max. rated)	238 kW (323 PS) @ 2000 rpm (DIN 6271)
	238 kW (318 HP) @ 2000 rpm (SAE J1349)
Torque (max.)	139 kgf.m (1363 Nm) @ 1300 rpm



Smooth and fast swing by increased swing torque

The swing drive minimises shocks during rotation while making increased torque available to ensure rapid cycles in the rough working place.

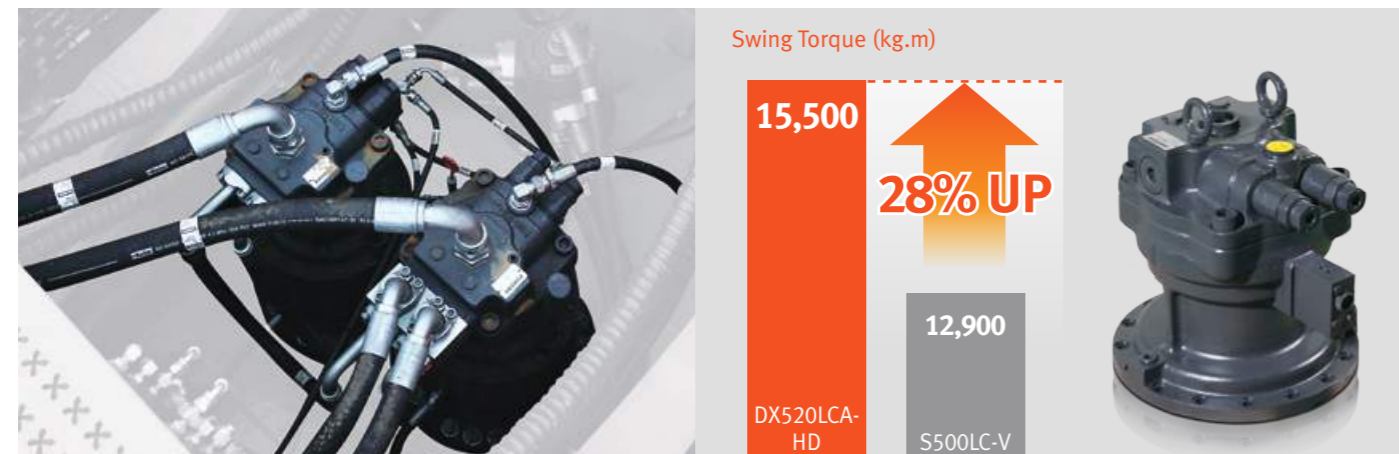

The industry's best machine stability

- 11.1 ton counter weight (the biggest)
- 3.9m wide retractable track (the widest)

Improved Excavator control by New e-EPOS™ system

The brains of the hydraulic excavator, the e-EPOS™ (Electronic Power Optimizing system), have been improved, through a CAN (Controller Area Network) communication link, enabling a continuous exchange of information between the engine and the hydraulic system. These units are now perfectly synchronised.

The advantages of the new e-EPOS™ impacts at several levels, Ease of operation and user-friendliness:

- The availability of a power mode and standard mode guarantee maximum efficiency under all conditions.
- The automatic deceleration mode enables fuel saving.
- Regulation and precise control of the flow rate required by the equipment are available as standard.
- A self-diagnosis function enables technical problems to be resolved quickly and efficiently.
- An operational memory provides a graphic display of the status of the machine.
- Maintenance and oil change intervals can be displayed.

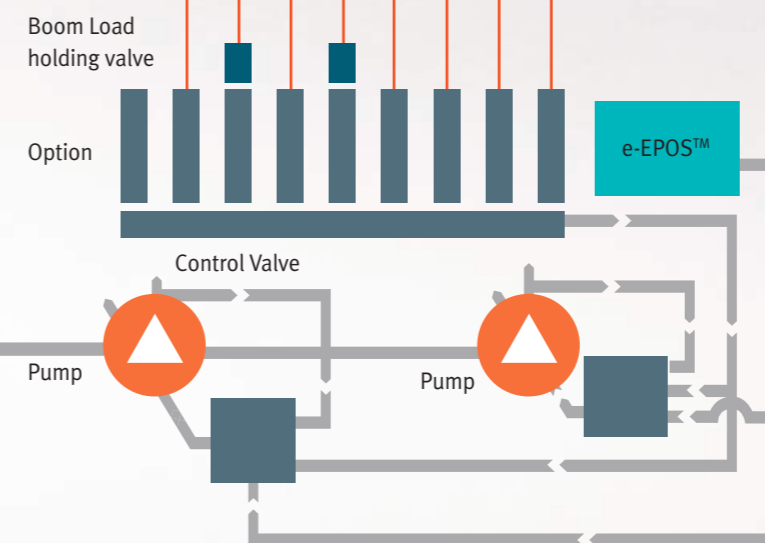



RELIEF CUTOFF

to prevent transfer of unnecessary flow

1. Typically, the pump tends to supply flow even when the maximum pressure on the system is reached due to severe working environments and large workloads.
2. Relief cutoff technology of Doosan prevent transfer of unnecessary flow to keep powerful working level at the maximum value while reducing consumption of fuel.

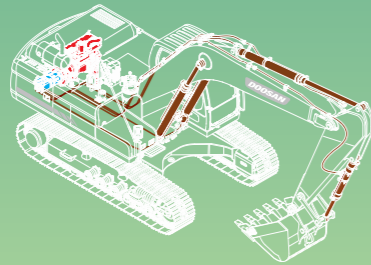

RELIEF CUTOFF

Relief cutoff technology saves 20~30% of fuel consumption in the heavy workload.



OPTIMIZED LEVER CONTROL

to prevent unnecessary fuel consumption

1. When operator takes break for rest with the joystick kept fixed, both of the engine and the pump are kept in standby mode with maximum rotation rate and hydraulic power. In such a case, unnecessary fuel consumption takes place.

& AUTO IDLE

2. The auto idle technology effectively controls the engine, and prevents unnecessary fuel consumption while the engine is kept in standby mode. Further, the optimized lever control technology effectively controls the pump to keep power of the pump maximum and prevent fuel consumption while the system is kept shut down.

When operating the joystick, rotation rate of the engine and maximum hydraulic power of the pump increase simultaneously for efficient consumption of fuel. The technologies of Doosan enable operation of the system with maximum power in time.

OPTIMIZED LEVER CONTROL

In auto idle, you can save 90% of fuel than in operation.

Fuel consumption in operation



Fuel consumption in auto idle



ENGINE & PUMP MATCHING

to reduce matching response time of the system

1. It is common that response time of the system (time for generating rated power from the minimum power) is slower than response speed of the pump. In such a case, the pump is kept in standby mode until the engine reaches the rated power to cause unnecessary fuel consumption. In addition, more fuel is supplied to the engine for matching the pump speed with the engine to result in more exhaust fumes.
2. Engine & pump matching, the new technology of Doosan, fully resolves these problems. Matching response time between pump and engine efficiently reduces unnecessary fuel consumption as well as exhaust fumes.

ENGINE & PUMP MATCHING

Matching response time between pump and engine makes higher performance with reduced fuel consumption.

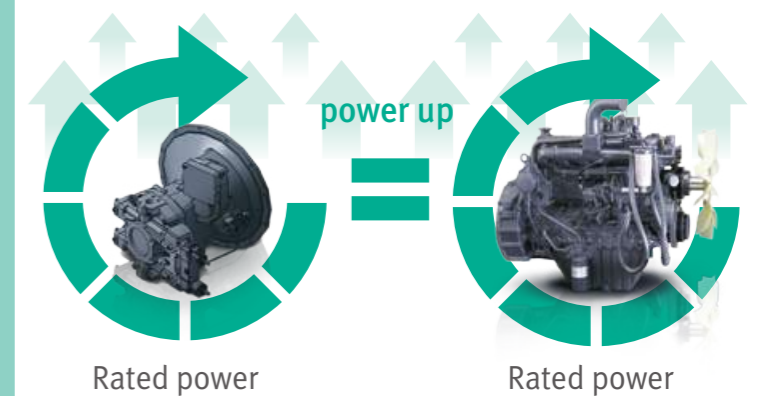

Doosan Efficient Dynamics Features

“NEW CONTROL LOGIC” for Better Fuel Efficiency

Handling & Comfort

1 Gauges

2 Navigation modes, Rear view camera, Display selector

3 Working modes, auto-idle & flow rate control



More space, better visibility, air conditioning with climate control, a very comfortable seat... These are the elements that ensure the operator can work in the best possible conditions. Furthermore, a new, user-friendly colour 7" TFT LCD monitor panel gives full access to machine settings and maintenance data allowing you to work safely and confidently with an accurate overview of all conditions.



3 Work modes to suit your application

- 1-way mode
- 2-way mode
- Digging mode

3 Power modes for maximum efficiency

- Power mode
- Standard mode
- Economy mode



Control panel

The control panel is clear, simple to read and positioned for easy use, allowing you to work safely and confidently.

Simple operation

Levelling operations, movement of lifted loads and tricky manoeuvres are all controlled easily and precisely with control levers. Buttons integrated on the levers are used to operate additional equipment such as grabs, crushers and grapples and activate the power boost function.

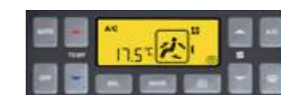
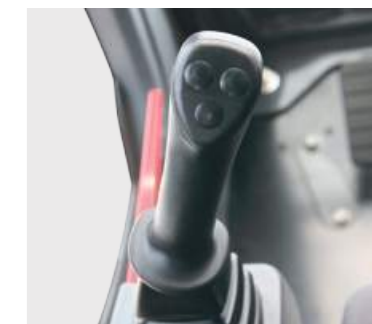

Air conditioning with climate control

High performance, electronically controlled air conditioning features 5 different operating modes allowing the operator to adjust the airflow to suit conditions. A re-circulated air function is also available. Temperature is adjustable from 17°C (62°F) to 32°C (90°F) by 0.5°C (1°F) increments.



Spacious, comfortable, newly designed cab

The cab is mounted on special viscous vibration isolators which absorb shocks and limit noise for more operator comfort.



- 1 Comfortable 2-stage sliding seat
- 2 Control stand (Telescopic Function)



Other features

- 1 Mobile phone compartment
- 2 12V power socket
- 3 Heated air suspension seat (option)
- 4 Cigarette lighter
- 5 Glass antenna
- 6 Rear camera (option): a clear view of what's happening behind the machine adds safety and peace of mind.



Accessible parts Access to the various radiators is very easy, making cleaning simpler. Engine parts can be easily reached via the top and side panels.



Fuel pre-filter with water separator
High efficiency fuel filtration is attained by the use of multiple filters. These include a fuel prefilter fitted with a water separator that removes moisture, dirt and debris from the fuel. A fuel drain valve has been installed to facilitate maintenance.



Air filter with pre-filtered dust separator
The large capacity forced air cleaner removes over 99% of airborne particles. This reduces the risk of engine contamination and makes cleaning and cartridge change intervals greater. The pre-cleaning system uses centrifugal force to eliminate dust.



Remote greasing points
To make maintenance easier, the arm and boom greasing points have been centralised. Remote & grouped greasing points on boom & arm.

Protective oil return filter
Protection for the hydraulic system is made more effective by the use of glass fibre technology in the main oil return filter. With more than 99.5% of foreign particles filtered out, the oil change interval is increased.



Convenient fuse box
The fuse box is located in the storage compartment behind the seat, providing a clean environment and convenient access.



PC monitoring
A PC monitoring function enables connection to the e-EPOS system. Thus, various parameters can be checked during maintenance, including pump pressures, engine rotation and engine speed. These can be stored and printed for analysis.



Lower-hanging cabin door handle



New battery box
a. Larger anti-slip surface
b. New spring to facilitate fixing
c. Cut-off switch easier to reach
d. New locking device



New handrail & guardrail
The new fittings are now ISO 2867:2007 compliant. Access is facilitated and the fittings have been strongly reinforced.



Cat walk (platform) as standard on DX480LCA-HD & DX520LCA-HD
Larger anti-slip surface on the upper structure for more safety.

Technical specifications

Engine

Model

DOOSAN DE12TIS
4-Cycle Air-To-Air Intercooler In-line
Water-Cooled, Direct Injection, Tier I/Tier II

No. of cylinders

6

Rated horse power

238 kW (323 PS) at 2,000 rpm (DIN 6271)
238 kW (318 HP) at 2,000 rpm (SAE J1349)

Max. torque

139 kgf/m (1363 Nm) at 1300 rpm

Idle (low - high)

1000 [+/-25] - 2250 [+/-50] rpm

Piston displacement

11051 cm³

Bore x stroke

123 mm x 155 mm

Starter

24 V / 6.6 kW

Batteries

2 x 12 V / 150 Ah

Air filter

Double element and pre-filtered Turbo with auto dust evacuation.

Undercarriage

Very robust construction of all chassis elements. All welded structures designed to limit stresses. High-quality, durable materials. Lateral chassis welded and rigidly attached to undercarriage. Track rollers lubricated for life. Idlers and sprockets fitted with floating seals. Track shoes made of induction-hardened alloy with triple grouser. Heat-treated connecting pins. Hydraulic track adjuster with shock-absorbing tension mechanism.

NUMBER OF ROLLERS AND TRACK SHOES PER SIDE

Upper rollers (standard shoe)	1 (ø180 mm) + 2 (ø200 mm)
Lower rollers:	9 (ø200 mm)
Track shoes and links:	53
Overall track length:	5,465 mm

Hydraulic System

The brain of the excavator is the e-EPOS (Electronic Power Optimizing System). It allows the efficiency of the hydraulic system to be optimised for all working conditions and minimises fuel consumption. The e-EPOS is connected to the engine's electronic control unit (ECU) via a data transfer link to harmonise the operation of the engine and hydraulics.

- The hydraulic system enables independent or combined operations
- Two travel speeds offer either increased torque or high speed
- Cross-sensing pump system for fuel savings
- Auto deceleration system
- Three operating modes, three power modes
- Button control of flow in auxiliary hydraulic circuits
- Computer-aided pump flow control

Main pumps

Parallel, Bent-axis, Piston
Max. flow: 2 x 360 l/min
Displacement: 186 cc/rev.
Weight: 195 kg

Pilot pump

Gear pump
Max. flow: 27.4 l/min
Displacement: 11.0 cc/rev.
Relief valve pressure: 40 kgf/cm²

Maximum system pressure

Implement (boom/arm/bucket):	
Work, travel	320 kg/cm ² [+10~0]
Rotation	300 kg/cm ²
Power	350 kg/cm ² [+10~0]

Hydraulic cylinders

Piston rods and cylinder bodies of high-strength steel. Shock-absorbing mechanism fitted in all cylinders for shock-free operation and extended piston life.

	Cylinders	Quantity	Bore x rod diameter x stroke (mm)
Boom		2	170 x 115 x 1,610
Arm		1	190 x 130 x 1,980
Bucket		1	170 x 115 x 1,341
Bucket (8 m arm)		1	120 x 80 x 1,060
Arm (6.3 m boom)		1	190 x 130 x 1,805

Fluid capacities

Fuel tank

620 l

Cooling system (radiator capacity)

29.5 l

Engine oil

28 l

Travel device

2 x 10 l

Swing drive

2 x 5 l

Hydraulic tank

390 l

Environment

Noise levels comply with environmental regulations (dynamic values).

Noise level LwA

Guaranteed: 111 dB(A) (2000/14/EC)

Operator LpA

76.0 dB(A) (ISO 6396)

Weight

	Shoe width (mm)	Operating weight (t)		Ground pressure (kgf/cm ²)	
		DX480LCA-HD	DX520LCA-HD	DX480LCA-HD	DX520LCA-HD
Triple grouser	600 (std)	48.4	51.1	0.84	0.88
	750	49.4	52.1	0.68	0.72
	800	49.7	52.3	0.64	0.68
Double grouser	900	50.2	52.9	0.58	0.61
	600	48.4	51.1	0.84	0.88

Digging forces (ISO)

DX480LCA-HD		Boom: 7,100 mm Arm: 3,350 mm H CLASS Bucket: 2.07 m ³		Boom: 7,100 mm Arm: 2,900 mm H CLASS Bucket: 2.35 m ³		Boom: 7,100 mm Arm: 3,980 mm GP Bucket: 1.8 m ³	
		t	27.5/ 30.0	27.5/ 30.0	28.1/ 30.8		
BUCKET (Normal/Boost)	kN	269/ 294	269/ 294	276/ 302			
ARM (Normal/Boost)	t	20.7/ 22.6	23.5/ 25.7	18.6/ 20.3			
	kN	203/ 222	231/ 252	182/ 199			

DX520LCA-HD		Boom: 6,300 mm Arm: 2,900 mm H CLASS Bucket: 2.91 m ³		Boom: 6,300 mm Arm: 2,400 mm H CLASS Bucket: 3.28 m ³		Boom: 11,000 mm Arm: 8,000 mm GP Bucket: 0.92 m ³	
		t	27.5/ 30.0	27.5/ 30.0	13.8/ 15.2		
BUCKET (Normal/Boost)	kN	269/ 294	269/ 294	135/ 149			
ARM (Normal/Boost)	t	23.5/ 25.7	27.3/ 29.9	10.9/ 11.9			
	kN	231/ 252	268/ 293	107/ 117			

Swing Mechanism

- High-torque, axial piston motor with planetary reduction gear bathed in oil
- Swing circle is a single-row, shear type ball bearing with induction-hardened internal gear
- Internal gear and pinion immersed in lubricant
- Swing speed: 0 to 9.2 rpm
- Max. swing torque (Eff. = 0.77%): 20,130 (15,500) kgf/m

Drive

Each track is driven by an independent, high-torque axial piston motor through a planetary reduction gearbox. Two levers or foot pedals guarantee smooth travel with counter-rotation on demand.

Travel speed (low - high)

3.2 / 5.6 km/h

Maximum traction force

37.6 / 18.9 t (Eff. = 85 / 75%)

Maximum gradeability

35° (70%)

Technical specifications

Bucket

Bucket Type	Capacity (m ³)	Width (mm)		Weight (kg)	DX480LCA-HD Wide 3.90 m - CW: 8.5 t				DX480LCA-HD Fixed 3.59 m - CW: 9.0 t			DX480LCA-HD Narrow 3.57 m - CW: 9.0 t	
					Boom				Arm			Shoe	
					7.1 m HD	7.1 m	7.1 m HD	7.1 m	3.35 m HD	3.98 m	3.35 m HD	3.98 m	3.35 m HD
GP	1.80	1,474	1,381	1,718	A	A	A	A	A	B	B	A	A
	2.14	1,682	1,588	1,910	A	A	A	A	C	C	B	B	
	2.39	1,837	1,744	2,027	B	B	A	B	D	D	C	C	
	2.86	2,130	2,037	2,279	D	D	C	C	X	X	D	D	
H CLASS	1.80	-	1,200	1,689	A	A	A	A	A	B	A	A	
	2.07	-	1,350	1,800	A	A	A	A	C	C	A	B	
	2.35	-	1,500	1,960	A	B	A	B	D	D	B	C	
	2.72	-	1,700	2,108	C	C	B	C	D	-	C	D	
2.91	-	1,800	2,232	D	D	C	C	-	-	D	D		
Maximum load pin-on(payload+bucket)					6,967	6,537	7,272	6,823	5,475	5,147	6,222	5,845	

Bucket Type	Capacity (m ³)	Width (mm)		Weight (kg)	DX520LCA-HD Wide 3.90 m - CW: 11.1 t				DX520LCA-HD Fixed 3.59 m - CW: 11.1 t				DX520LCA-HD Narrow 3.57 m - CW: 11.1 t			
					Boom				Arm				Shoe			
					6.3m HD	6.3m HD	11.1m	6.3m HD	6.3m HD	11.1m	6.3m HD	6.3m HD	11.1m	6.3m HD	6.3m HD	11.1m
DC	1.12	-	1,500	1,002	X	X	X	X	X	X	X	X	X	X	X	X
	1.37	-	1,800	1,117	X	X	X	X	X	X	X	X	X	X	X	X
	0.92	1,236	1,173	697	X	X	A	X	X	A	X	X	D	X	X	C
GP	1.80	1,474	1,381	1,718	A	A	X	A	A	X	A	A	X	A	A	X
	2.14	1,682	1,588	1,910	A	A	X	A	A	X	A	A	X	A	A	X
	2.39	1,837	1,744	2,027	A	A	X	A	A	X	A	A	X	A	A	X
	2.86	2,130	2,037	2,279	A	A	X	A	A	X	A	A	X	A	A	X
H CLASS	1.80	-	1,200	1,689	A	A	-	A	A	-	A	A	-	A	A	-
	2.07	-	1,350	1,800	A	A	-	A	A	-	A	A	-	A	A	-
	2.35	-	1,500	1,960	A	A	-	A	A	-	A	A	-	A	A	-
	2.72	-	1,700	2,108	A	A	-	A	A	-	A	A	-	A	A	-
	2.91	-	1,800	2,232	A	A	-	A	A	-	A	A	-	A	A	-
	3.28	-	2,000	2,380	B	B	-	B	B	-	B	B	-	B	B	-
Maximum load pin-on(payload+bucket)					11,237	10,490	2,764	11,621	10,852	2,923	8,875	8,287	1,889	9,882	9,228	2,121

A : Suitable for materials with density of 2100kg/m³ (3500lb/yard³) or less
 C : Suitable for materials with density of 1500kg/m³ (2500lb/yard³) or less
 Based on ISO 10567 and SAE J296, arm length without quick change clamp.

B : Suitable for materials with density of 1800kg/m³ (3000lb/yard³) or less
 D : Suitable for materials with density of 1200kg/m³ (2000lb/yard³) or less

X: Not recommended

This bucket recommendation is based on machine stability considering the tipping load with a certain density of handling material and should be strictly followed. It's more recommendable to use a smaller size of bucket than that recommended, in severe working conditions and applications to ensure extended durability.

Standard and optional equipment

Standard equipment

ENGINE

- DOOSAN DE12TIS Diesel engine combined with e-EPOS System, Direct injection, water-cooled, Tier I/Tier II compliant
- Auto-idle function

HYDRAULIC SYSTEM

- Boom and arm flow regeneration
- Swing anti-rebound valves
- Spare ports (valve)
- One-touch power boost function
- Breaker piping
- Cylinder cushioning & contamination seals
- Control of auxiliary hydraulic flow from the display panel

CAB & INTERIOR

- Sound-insulated and viscous support mounted cab
- Seat with adjustable headrest and armrest
- Roof window
- Air conditioning with climate control
- Pull-up type front window with sun roller blind and removable lower front window
- Sliding left front window
- Intermittent upper windshield wiper
- Automatic rear window defroster
- Adjustable PPC wrist control levers for arm, boom, bucket and swing and auxiliary hydraulic buttons
- Travel pedals and hand levers
- 7" (18 cm) LCD colour monitor panel
- Engine speed (RPM) control dial
- 3 operating modes & 3 working modes
- Seat belt
- Cigarette lighter and ashtray
- Ceiling light
- Cup holder
- Multiple storage compartments
- Tool storage area
- Hot and cool box
- Flat, spacious, easy-to-clean floor
- Master key
- Anti-theft protection
- Loudspeakers and connections for radio
- Remote radio audio control panel
- 12 V spare power socket
- Serial communication port for laptop PC interface
- MP3/USB radio with CD player

SAFETY

- Large handrails, steps and platform
- Parking brake and cab swing lock pin
- Punched metal anti-slip plates
- Hydraulic safety lock lever
- Safety glass
- Hammer for emergency escape
- Reinforced cast steel pivot points
- Lockable fuel cap and covers
- Battery cut-off switch
- Emergency engine stop and hydraulic pump control switches
- Engine overheat prevention system
- Engine restart prevention system
- Plastic roof cover
- Light rearview mirror

OTHER

- Boom DX480LCA-HD: 7.1 m HD – arm: 3.35 m HD / Boom DX520LCA-HD: 6.3m HD Boom – 2.4m/2.9m HD Arm
- Counterweight DX480LCA-HD: 8,500 kg / DX520LCA-HD: 11,100 kg
- Tropical area preparation
- Well protected and optimised layout of hydraulic, electric & lubrication routing
- Double element air cleaner and pre-filtered Turbo dust separator
- Fuel filter + fuel pre-filter with water separator sensor
- Fuel filling pump
- Dust screen for radiator/oil cooler
- Self-diagnostic function
- Work lights (2 front frame, 2 front cab-mounted, 2 boom-mounted and 1 rear side) with alternator (12 V, 50 A)
- Electric horn
- Hydrostatic 2-speed travel system with automatic shift
- Remote greasing for swing circle and workgroup pivot points
- Breaker piping & Filter
- HD under cover
- EM bush

UNDERCARRIAGE

- Variable undercarriage 3.34 m - 3.90 m (mechanically adjustable)
- Hydraulic adjuster for the track
- Full track guard
- Greased and sealed track links
- 600 mm triple grouser shoe

Optional equipment

CAB & INTERIOR • ROPS CABIN AIR • SUSPENSION SEAT

- Heated, adjustable air suspension seat with adjustable headrest and armrest
- Rain shield
- Joystick pattern change

SAFETY

- FOGS cab - top and front cab guards (ISO 10262)
- Front window upper and lower guards
- Boom and arm cylinder safety valves
- Overload warning device
- Rotating beacon or telescopic rotating beacon
- Rear view and side camera
- Travel and swing alarm
- Additional right rearview mirror

OTHER

- Arms DX480LCA-HD: 2.40 m HD, 2.90 HD or 3.98 m
- Arms DX520LCA-HD: 3.35 or 8.00 m SLR - boom: 11.00 m SLR
- Fuel heater
- Hydraulic piping for crusher, quick coupler, clamshell, tilting and rotating buckets
- Floating boom function
- Wiper for lower front window
- Double pump flow
- Oil-washed air cleaner
- Toolkit and spare parts for first service
- 6 additional work lights (2 front frame, 4 front cab-mounted, 2 rear cab-mounted, 2 boom-mounted and 1 rear side) with alternator (24 V, 80 A)
- Guards for work lights (boom)

UNDERCARRIAGE

- 600 mm double grouser shoe & 750, 800 & 900 mm triple grouser shoe
- Full length track guard



FULL LENGTH TRACK GUARD
For extra protection against track slippage.



FOGS CAB OR FRONT GUARDS
For extra safety in specific applications.



SUPER LONG REACH - SLR AND SEMI SLR
Our long reach machines are ideally suited for land and water based operations with a maximum reach of nearly 20 metres.



OIL-WASHED AIR CLEANER
Increases cleaning of the air intake in extra dusty areas such as quarries.

Some of these options may be standard in some markets. Some of these options may not be available for certain markets. Please check with your local DOOSAN dealer for more information about availability or to adapt your machine to your application needs.

Dimensions

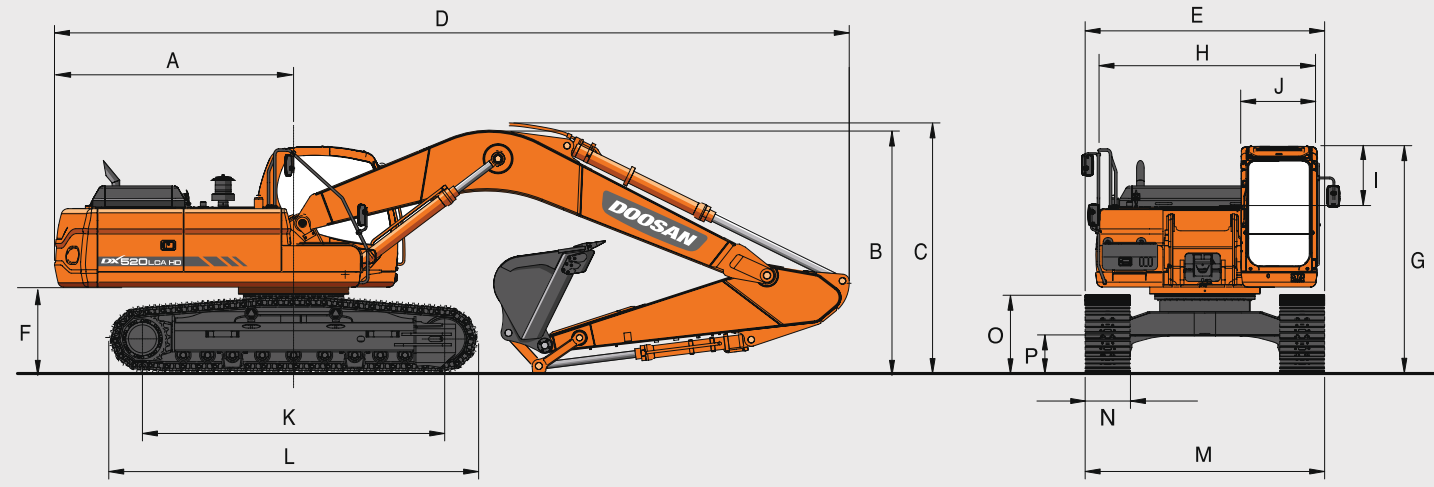

Dimensions

	DX480LCA-HD				DX520LCA-HD			
	7,100	7,100	6,300	11,000	7,100	7,100	6,300	11,000
Boom length - mm	7,100	7,100	6,300	11,000	7,100	7,100	6,300	11,000
Arm length - mm	3,500	2,900	3,980	3,350	2,900	2,400	8,000	3,350
Bucket capacity - m ³	2.14	2.39	1.80	2.14	3.20	3.60	0.92	2.39
Undercarriage	Variable				Variable			
A. Tail swing radius - mm	3,700	3,700	3,700	3,700	3,700	3,700	3,700	3,700
B. Shipping height (boom) - mm	3,580	3,830	3,840	3,570	4,140	4,010	3,840	3,990
C. Shipping height (hose) - mm	3,730	3,980	3,990	3,720	4,200	4,100	4,070	4,125
D. Shipping length - mm	12,130	12,230	12,210	12,180	11,430	11,620	16,090	12,130
E. Shipping width (std) - mm	3,340	3,340	3,340	3,350	3,340	3,340	3,340	3,340
F. Counterweight clearance - mm	1,460	1,460	1,460	1,460	1,460	1,460	1,460	1,460
G. Height over cab - mm	3,350	3,350	3,350	3,350	3,350	3,350	3,350	3,350
H. House width - mm	2,990	2,990	2,990	2,990	2,990	2,990	2,990	2,990
I. Cab height above house - mm	845	845	845	845	845	845	845	845
J. Cab width - mm	1,010	1,010	1,010	1,010	1,010	1,010	1,010	1,010
K. Tumbler distance - mm	4,470	4,470	4,470	4,470	4,470	4,470	4,470	4,470
L. Track length - mm	5,465	5,465	5,465	5,465	5,465	5,465	5,465	5,465
M. Undercarriage width (std) - mm	3,340 / 3,900*	3,340 / 3,900*	3,340 / 3,900*	3,340 / 3,900*	3,340 / 3,900*	3,340 / 3,900*	3,340 / 3,900*	3,340 / 3,900*
N. Shoe width - mm	600	600	600	600	600	600	600	600
O. Track height - mm	1,210	1,210	1,210	1,210	1,210	1,210	1,210	1,210
P. Ground clearance - mm	770	770	770	770	770	770	770	770

(*) Retracted / Extended

Component weights

Item	unit	DX480LCA-HD	DX520LCA-HD	Remarks
Upper structure without front	kg	18,300	20,900	with counterweight
Counterweight	kg	8,500	11,100	
Lower structure assembly	kg	19,300	19,300	
Front assembly	kg	10,500	10,800	based on standard *
Boom 6,300 mm	kg	3,470	3,470	
Boom 7,100 mm	kg	3,825	3,825	
Boom 11,000 mm	kg	-	4,500	SLR
Arm 2,400 mm	kg	1,530	1,530	
Arm 2,900 mm	kg	1,600	1,600	including bushing
Arm 3,350 mm	kg	1,830	1,830	
Arm 3,980 mm	kg	1,850	-	SLR
Arm 8,000 mm	kg	-	2,460	
Bucket	kg	1,935 (2.14 m ³ GP)	2,590 (3.20 m ³ HD)	
Boom cylinder (each)	kg	400	400	
Arm cylinder	kg	610	610	
Bucket cylinder	kg	370	370	150 kg for DX520LCA-HD 8.0 m arm

(*) : DX480LCA-HD Std front – 7.1 m Boom, 3.35 m Arm, 2.14 m³ GP Bucket.
DX520LCA-HD Std front – 6.3 m Boom, 2.90 m Arm, 3.20 m³ HD Bucket.

Lifting capacities

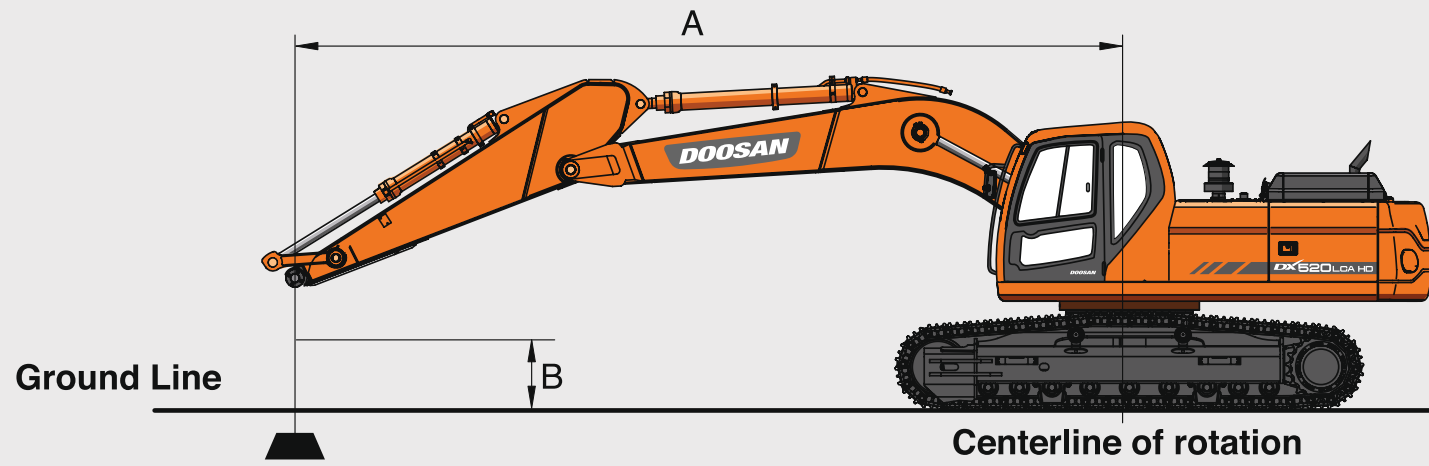

DX480LCA-HD – Standard configuration

Standard track: 3,900 mm - HD Boom: 7,100 mm - HD Arm: 3,350 mm - Without bucket - Shoe: 600 mm - Counterweight: 8,500 kg Units: 1,000 kg

A(m)	3	4-5	6	7-5	9	Max. Reach	A(m)
B(m)							
9.0				10.83*	10.83*	8.47*	7.89
7.5				10.81*	10.81*	8.03*	8.94
6.0				11.49*	11.49*	7.90*	9.65
4.5		20.23*	20.23*	15.08*	12.54*	12.21*	10.09
3.0		21.91*	21.91*	17.18*	11.2	13.68*	10.68*
1.5		17.00*	17.00*	18.65*	10.96	14.48	10.22
o(Ground)		21.26*	21.26*	19.19*	10.77	14.15	9.92
-1.5	17.07*	17.07*	24.59*	21.63	18.78*	10.72	9.8
-3.0	26.20*	26.20*	22.23*	21.9	17.36*	13.69*	9.86
-4.5	23.09*	23.09*	18.42*	18.42*	14.51*	14.03	10.68*

Option 1

Standard track: 3,900 mm - HD Boom: 7,100 mm - HD Arm: 3,980 mm - Without bucket - Shoe: 600 mm DG - Counterweight: 8,500 kg Units: 1,000 kg

A(m)	1.5	3	4-5	6	7-5	9	10.5	Max. lift	A(m)
B(m)									
9.0								7.16*	7.16*
7.5								6.85*	6.85*
6.0								6.77*	6.77*
4.5								9.76*	8.99
3.0								10.78*	10.78*
1.5								10.04*	8.84
o(Ground)								14.10*	14.10*
-1.5	13.14*	13.14*	16.76*	16.76*	25.63*	21.66	19.16*	13.68	14.09
-3.0	19.05*	19.05	23.78*	23.78*	23.79*	21.82	18.20*	13.68	14.07
-4.5			27.31*	27.31*	20.61*	20.61*	16.03*	13.92	12.43*
-6.0					15.32*	15.32*	11.67*	11.67*	10.06

1. The nominal forces are based on the SAE J1097 standard.
2. The load point is the hook at the rear of the bucket.
3. * = The nominal loads are based on hydraulic capacity.

4. The nominal loads shown do not exceed 75% of tipping loads or 87% of hydraulic lifting capacity.
5. For lifting capacity with bucket, simply subtract actual weight of the bucket from the values.
6. The configurations indicated do not necessarily reflect the standard equipment of the machine.

: Nominal force

: Nominal force at the side or 360°

DX520LCA-HD – Standard configuration

Standard track: 3,900 mm - HD Boom: 6,300 mm - HD Arm: 2,900 mm - Without bucket - Shoe: 600 mm - Counterweight: 11,100 kg Units: 1,000 kg

A(m)	3	4-5	6	7-5	Max. lift	A(m)
B(m)						
7.5					12.57*	12.57*
6.0					12.40*	11.65
4.5					12.70*	10.4
3.0					12.89*	9.81
1.5					12.12	9.7
o(Ground)					13.48*	10.06
-1.5	25.15*	25.15*	27.18*	26.21*	20.10*	16.73
-3.0	29.17*	29.17*	22.35*	22.35*	17.12*	16.81

Option 1

Standard track: 3,900 mm - HD Boom: 6,300 mm - HD Arm: 2,400 mm - Without bucket - Shoe: 600 mm - Counterweight: 11,100 kg Units: 1,000 kg

A(m)	3	4-5	6	7-5	Max. lift	A(m)
B(m)						
7.5					13.94*	13.94*
6.0					13.62*	12.67
4.5					13.60*	11.19
3.0					13.73*	10.51
1.5					13.96*	10.4
o(Ground)					16.68	16.68
-1.5					26.61*	26.16
-3.0	25.43*	25.43*	20.61*	20.61*	15.81*	15.81*

Option SLR

Standard track: 3,900 mm - Boom: 11,000 mm - Arm: 8,000 mm - Without bucket - Shoe: 600 mm - Counterweight: 11,100 kg Units: 1,000 kg

A(m)	1.5	3	4-5	6	7-5	9	10.5	12	13.5	15	16.5	18	Max. lift	A(m)
B(m)														
12													3.21*	3.21*
10.5													3.92*	3.92*
9													3.99*	3.99*
7.5													4.12*	4.12*
6													4.02*	3.54
4.5													4.53*	4.53*
3.0													4.30*	4.23
1.5													4.13*	3.44
o													4.83*	4.83*
-1.5	6.26*	6.26*	6.91*	6.91*	9.21*	9.21*	13.88*	12.56	11.89*	9.23	9.53*	7.21	7.94*	5.82
-3	7.68*	7.68*	8.46*	8.46*	10.53*	10.53*	14.59*	12.24	12.25*	8.89	9.88*	6.91	8.17	5.58
-4.5	9.15*	9.15*	10.08*	10.08*	12.13*	12.13*	15.74*	12.14	12.34*	8.72	9.99	6.73	8.01	5.42
-6	10.70*	10.70*	11.81*	11.81*	13.99*	13.99*	15.35*	12.19	12.18*	8.69	9.92	6.67	7.93	5.35
-7.5	12.37*	12.37*	13.71*	13.71*	16.13*	16.13*	14.65*	12.37	11.76*	8.77	9.71*	6.7	7.95	5.36
-9	14.19*	14.19*	15.84*	15.84*	17.47*	17.47*	13.61*	12.67	11.04*	8.96	9.17*	6.83	7.73*	5.47
-10.5	16.22*	16.22*	18.29*	18.29*	15.32*	15.32*	12.13*	12.13*	9.94*	9.26	8.28*	7.06	6.93*	5.67
-12													5.74*	4.73
-13.5													5.68*	5.68*

1. The nominal forces are based on the SAE J1097 standard.
2. The load point is the hook at the rear of the bucket.
3. * = The nominal loads are based on hydraulic capacity.

4. The nominal loads shown do not exceed 75% of tipping loads or 87% of hydraulic lifting capacity.
5. For lifting capacity with bucket, simply subtract actual weight of the bucket from the values.
6. The configurations indicated do not necessarily reflect the standard equipment of the machine.

: Nominal force

: Nominal force at the side or 360°

Working range

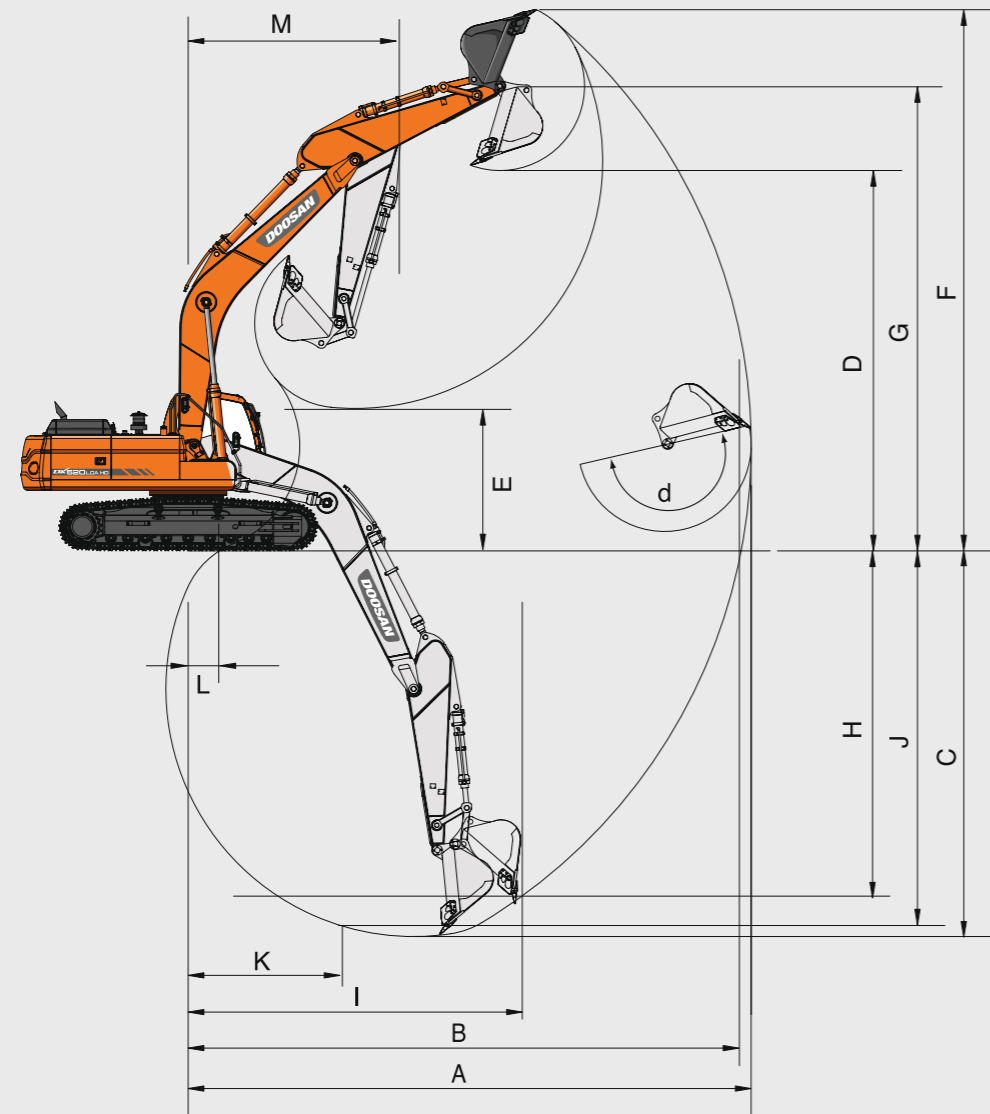

Working range

	DX480LCA-HD				DX520LCA-HD				
	7,100		6,300		6,300		11,000		7,100
Boom length - mm									
Arm length - mm	3,350	2,900	3,980	3,350	2,900	2,900	2,400	8,000	3,350
Bucket capacity - m ³	2.14	2.39	1.80	1.71	2.86	3.20	3.60	0.92	2.39
Undercarriage	Variable				Variable				
A. Max. digging reach - mm	12,120	11,720	12,670	12,150	10,770	10,750	10,330	19,610	12,120
B. Max. digging reach at ground level - mm	11,870	11,460	12,430	11,900	10,480	10,460	10,030	19,460	11,870
C. Max. digging depth - mm	7,810	7,360	8,440	7,850	6,810	6,770	6,270	15,130	7,810
D. Max. dumping height - mm	7,880	7,730	8,040	7,850	6,595	6,720	6,620	11,950	7,880
E. Min. dumping height - mm	3,125	3,580	2,500	3,110	2,930	2,950	3,470	1,980	3,125
F. Max. digging height - mm	11,080	10,940	11,230	10,930	9,720	9,600	9,460	14,520	11,080
G. Max. bucket pin height - mm	9,705	9,560	9,850	9,720	8,520	8,520	8,402	10,735	9,705
H. Max. vertical wall depth - mm	4,410	4,080	4,964	5,310	2,920	1,190	590	12,840	4,410
I. Max. radius vertical - mm	9,970	9,705	10,235	9,319	9,310	10,100	9,840	9,730	9,970
J. Max. digging depth(8' level) - mm	7,675	7,200	8,320	7,700	6,610	6,590	6,070	15,020	7,675
k. Min. radius 8' line - mm	2,950	3,935	3,935	3,935	3,230	3,215	3,230	4,930	3,950
L. Min. digging reach - mm	880	2,050	80	820	1,140	1,240	2,060	270	880
M. Min. swing radius - mm	5,170	5,190	5,140	5,170	4,750	4,750	4,780	6,210	5,170
d. Bucket angle - deg.	174	174	174	174	176	174	176	178	174



Doosan worldwide factories

- Heavy Equipment Factory
- Compact Equipment Factory
- Attachment Factory

ILDESIGN_EN_201502

Materials and Specifications in the catalogue are subject to change without notice.



Doosan Infracore Korea Office (HQ)
27/F, Doosan Tower 18-12, Euljiro-6Ga, Jung-Gu
Seoul 100-730 Korea
Tel : 82 2 3398 8114

www.doosaninfracore.com/ce/